

Best viewed in landscape mode



THE iX3



#bornelectric

THE NEW BMW iX3.

RETURN BY CLICKING [🏠](#)
SELECT A TOPIC BELOW TO EXPLORE:



FEATURED MODEL. BMW iX3 PREMIER EDITION.

BMW eDrive electric motor, 286hp (210kW), 20" light alloy Aerodynamic style 843 wheels in Jet Black, exterior paint in Carbon Black, Adaptive LED headlights, exterior elements in BMW i Blue, seats in Black Vernasca leather with Grey stitching, High-gloss Black interior trim with Pearl Chrome highlight.

The new BMW iX3 is expected to be available from Summer 2021. For further details, please contact your local BMW Centre.

Content correct at time of publishing (as of March 2021). The models shown on these pages may feature optional equipment. Standard equipment may also vary depending on engine variant. For further details, please contact your local BMW Centre.

DISCOVER THE ELECTRIC EDGE.

"IT LANDS IN THAT CROSSOVER SWEET SPOT,
A COMPACT SUV, CAPABLE OF SEATING THE
WHOLE FAMILY, BUT STILL PRACTICAL ENOUGH
FOR URBAN DRIVING."

The BMW iX3: Everything you need to know
[Read full article here](#)



GO THE DISTANCE
LIKE NOTHING
BEFORE.



"IT HAS A FAB INFOTAINMENT SYSTEM
AND A SMART INTERIOR, SO IT'S A FINE
BUY IF YOU'RE LOOKING FOR A BIG SUV
THAT RUNS SOLELY ON ELECTRICITY."

What Car?

[Read full article here](#)

THE BMW iX3 PREMIER EDITION.



The new BMW iX3 Premier Edition is shown above in Carbon Black metallic paint

■ Standard equipment □ Optional equipment

THE BMW iX3 PREMIER EDITION.



EXTERIOR

- BMW i Blue decorative elements, comprising:
 - Kidney grille
 - Diffuser panel in rear bumper cover
- 20" light alloy Aerodynamic style 843 wheels, Jet Black
- Metallic paint
- Adaptive LED headlights
- Roof rails, High-gloss Shadowline
- eDrive exterior sound
- Exterior mirrors – electrically folding with anti-dazzle

INTERIOR

- Interior trim, High-gloss Black with Pearl Chrome finisher
- Sun protection glass
- Galvanic embellisher on controls
- Headlining, Anthracite
- Vernasca leather upholstery
- Instrument panel, Sensatec
- Seat adjustment – electric, with driver memory
- Seat heating, front
- Panoramic glass sunroof
- Ambient lighting with six selectable light designs
- Automatic air conditioning, three-zone
- Sport leather steering wheel, three-spoke
- Through-loading system
- Extended storage

BATTERY & CHARGING

- Mode 3 Charging Cable
- Connected Charging Digital Services
- BMW eDrive Motor
- Mode 2 standard charging cable (2.3kW)
- Mode 3 public charging cable (11kW)
- Fast charging AC multi-phase capability (11kW)
- DC Rapid Charging preparation (50kW)
- DC High-Power Charging preparation (150kW)

SAFETY & TECHNOLOGY

- BMW IconicSounds Electric composed by Hans Zimmer
- Adaptive suspension
- Parking Assistant
- Active Protection
- Driving Assistant Professional

AUDIO & COMMUNICATION

- BMW Live Cockpit Professional, comprising:
 - 10.25" Control Display with Touch Functionality
 - 12.3" Digital Cockpit Display
 - BMW Operating System 7.0
- Connected Package Professional
- Enhanced Bluetooth with wireless charging
- WiFi hotspot preparation

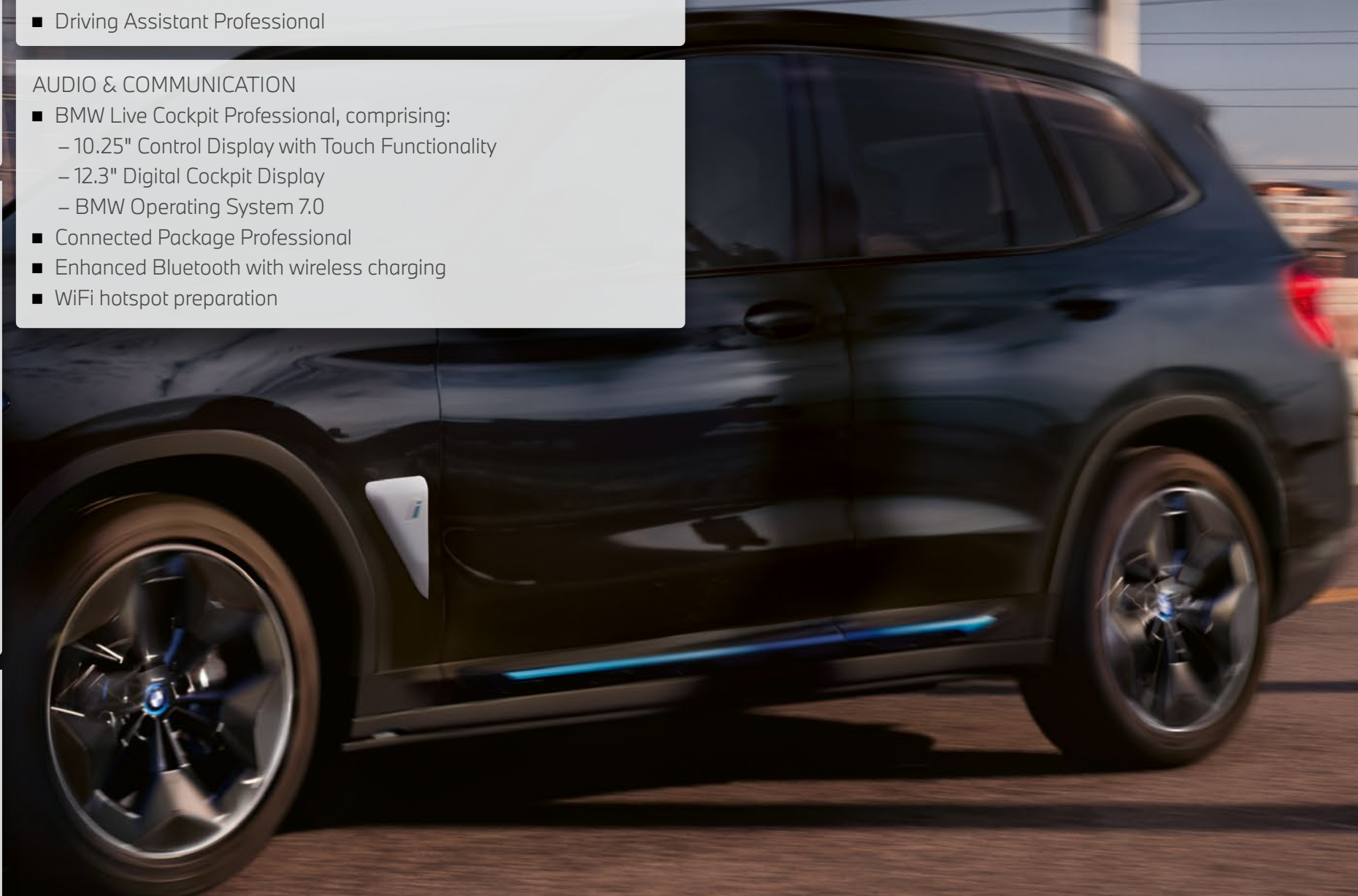

THE BMW iX3 PREMIER EDITION PRO.



The new BMW iX3 Premier Edition Pro is shown above in Carbon Black metallic paint

■ Standard equipment □ Optional equipment

THE BMW iX3 PREMIER EDITION PRO.



In addition / replacement to iX3 Premier Edition models
INTERIOR

- Comfort Access with smart-opener, comprising:
 - Digital Key¹
 - Welcome Light Carpet
 - Smart-opener for tailgate
 - Keyless access
 - Intelligent Automatic Unlocking
- Lumbar support, front
- Loudspeaker system - harman/kardon
- Acoustic glazing

SAFETY & TECHNOLOGY

- BMW Icon Adaptive LED Headlights
- High-Beam Assistant
- Parking Assistant Plus
- Drive Recorder
- Head-up Display
- BMW Gesture Control



The new BMW iX3 Premier Edition Pro is shown above in Carbon Black metallic paint ¹ = Available and active without runtime limitations. Usage cannot be guaranteed permanently due to potential future technical developments (of the Service availability and/or Smartphone compatibility/operating systems). A list of compatible Apple Smartphones is available at [bmw.com/digitalkey](https://www.bmw.com/digitalkey).

■ Standard equipment □ Optional equipment

EXTERIOR COLOURS.

ALL MODELS.



Metallic Mineral White



Metallic Sophisto Grey

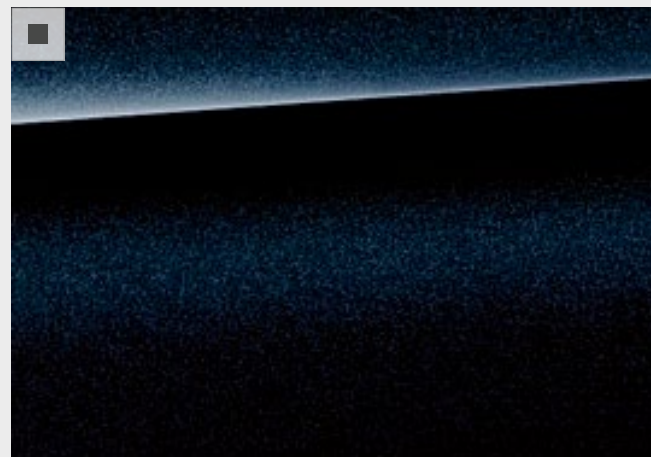

Metallic Carbon Black

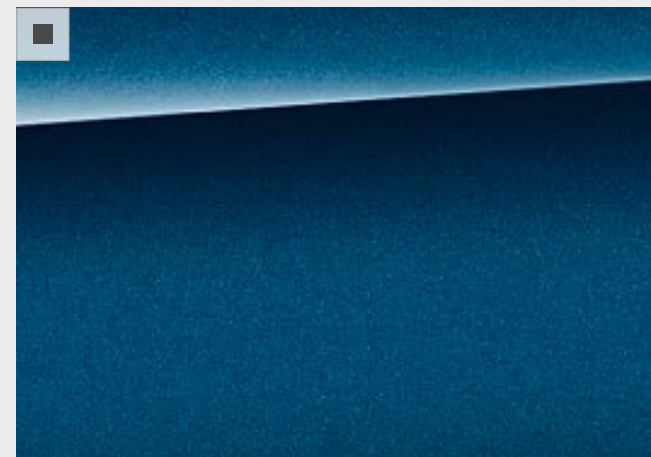

Metallic Phytonic Blue



Colour samples These colour samples are intended as an initial guide to the colours and materials available for your BMW. Please discuss your preferred colour choices with your BMW Centre. There you can also see original samples and be assisted with any requests.

■ Standard equipment □ Optional equipment

UPHOLSTERY & INTERIOR TRIMS.

LEATHER.



Vernasca leather in Black with Grey stitching

Available with

- iX3 Premier Edition
- iX3 Premier Edition Pro



Vernasca leather in Mocha with Blue stitching

Available with

- iX3 Premier Edition
- iX3 Premier Edition Pro

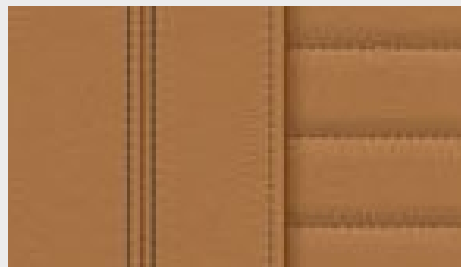

Vernasca leather in Cognac with Mocha stitching

Available with

- iX3 Premier Edition
- iX3 Premier Edition Pro



Vernasca leather in Canberra Beige with Roggen stitching

Available with

- iX3 Premier Edition
- iX3 Premier Edition Pro

INTERIOR TRIMS.

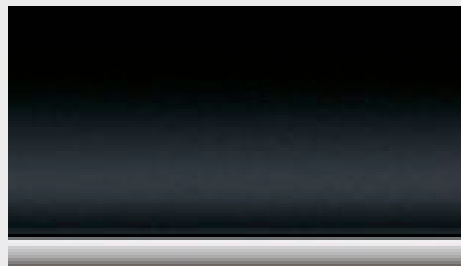

High-gloss Black with Pearl Chrome finisher

Available with

- iX3 Premier Edition
- iX3 Premier Edition Pro



Aluminium fine cutting with Pearl Chrome finisher

Available with

- iX3 Premier Edition
- iX3 Premier Edition Pro

STANDARD EQUIPMENT HIGHLIGHTS.

PANORAMIC GLASS SUNROOF.

Providing the most mesmerising views, the two-part electric Panoramic glass sunroof allows a great deal of light into the interior, lending it a particularly spacious and open ambience. It is electrically operated and features sun protection glass and a floating headlining. It can also be conveniently opened and closed with the vehicle key.



BMW LIVE COCKPIT PROFESSIONAL.

Enjoy the latest BMW multimedia and Navigation system. BMW Live Cockpit Professional features variable, configurable widgets that display information in real time. Functioning on the BMW Operating System 7.0, the high-resolution 10.25" Control Display, as well as the fully digital 12.3" Cockpit display, include intuitive operating options that help you to stay more connected than ever before.

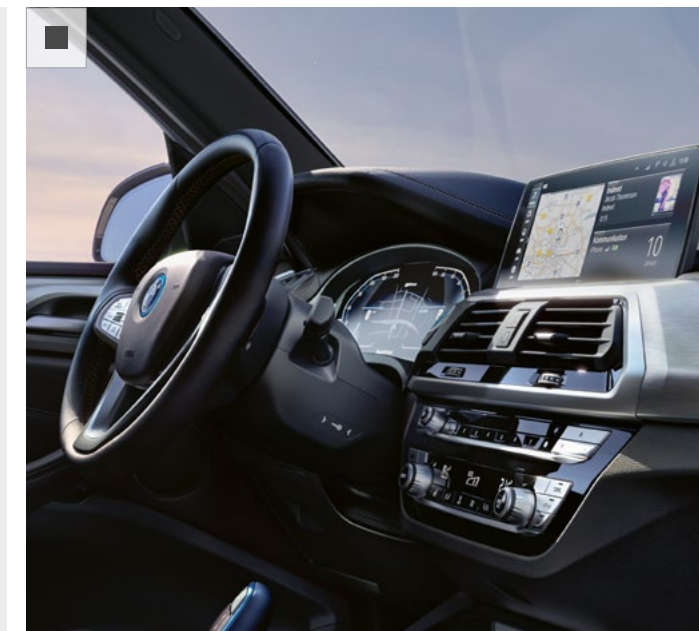

AERODYNAMIC WHEELS.

Expanding the capabilities of design and efficiency, the new aerodynamic alloy wheel design is standard for iX3 Premier Edition and Premier Edition Pro. As well as delivering enhanced performance, the 20" wheels also extend the range by up to 6 miles, this is thanks to a 15% weight reduction against conventional alloys.



ADAPTIVE SUSPENSION.

Improve driving dynamics, agility and comfort. The Adaptive suspension is a variable, electronically controlled shock absorber adjustment system. It features sensors in the vehicle that permanently measure body and wheel acceleration and lateral/longitudinal acceleration. The driving speed and the position of the steering wheel calculate the control commands for the electromagnetic valves in the shock absorbers for each individual wheel.

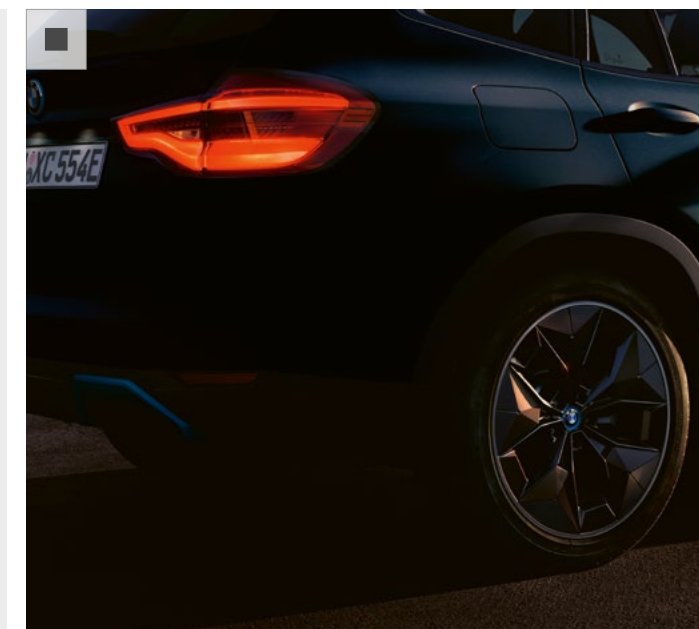

DRIVING ASSISTANT PROFESSIONAL.

Driving Assistant Professional offers optimum comfort and safety during monotonous or complex driving situations. It includes numerous functions to make your journey even safer and more enjoyable. Features include Active Cruise Control with approach control, Steering and Lane Control Assistant, Automatic Speed Limit Assistant (SLA), Lane Keeping Assistant with active side collision protection and Active Lane Guidance.

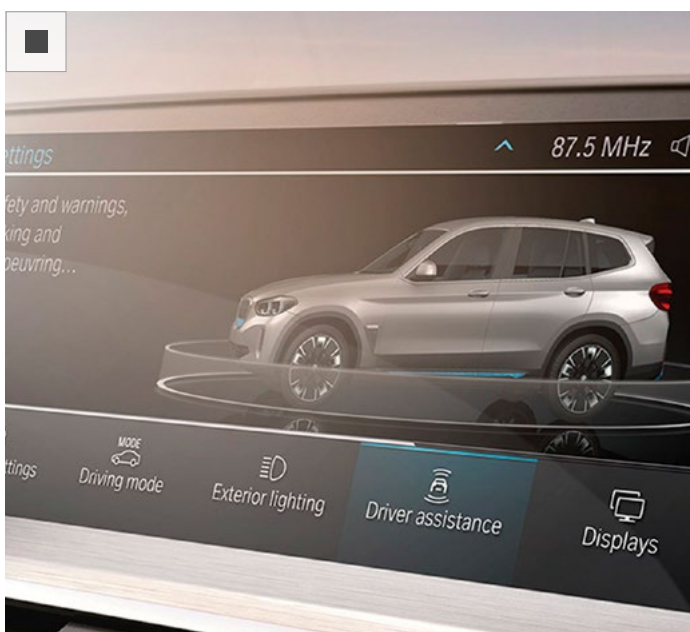

PARKING ASSISTANT PLUS.

Parking Assistant makes parking easier with Park Distance Control (PDC), Parking assistant, Reversing Assistant, Lateral Parking Aid and the Rear view camera. Parking assistant makes parking in parallel and lateral parking spaces easier as well as leaving a parking space parallel to the road.



BMW CONNECTED DRIVE.

BMW ConnectedDrive enables you to remain connected to the outside world from the comfort of your BMW.



■ BMW LIVE COCKPIT PROFESSIONAL

- **BMW Apps** makes it possible to operate apps such as BMW Connected.
- **BMW Emergency Call** automatically creates a direct link to the local emergency services.
- **BMW Intelligent Personal Assistant** understands natural speech. It interacts with your BMW and has the ability to learn driver preferences.
- **BMW Online Services** provides a seamless integration of personalised BMW Connected mobility-related services.
- **BMW Teleservices** supports the processing of servicing appointments and sends vehicle-specific service data to BMW.
- **Intelligent Functionalities** creates customised rules and learns the driver's habits to enable greater comfort on every journey.
- **Last State Call** transfers vehicle-based data to the BMW Connected App, allowing you to view current mileage, fuel status and other features from your phone.
- **Map updates** automatically updates the maps in your BMW by downloading them over the air.

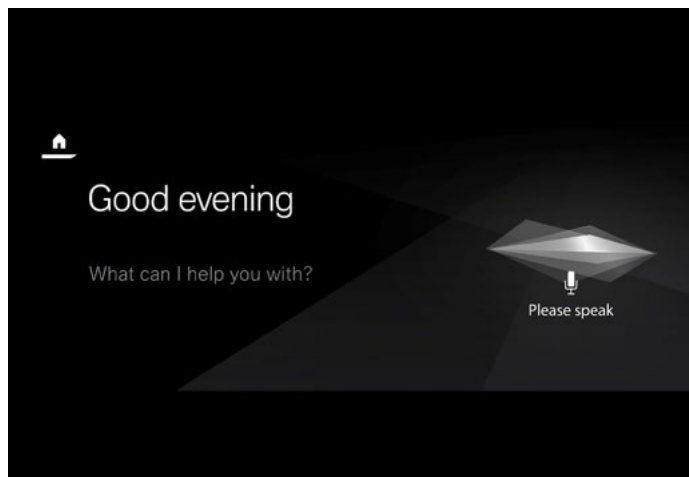

■ CONNECTED PACKAGE PROFESSIONAL.

- **BMW Maps** makes route planning easier, anticipates road conditions and provides an estimated time of arrival.
- **Concierge Services** connects the driver to a BMW Call Centre agent around-the-clock.
- **Connected Charging** enables the search and display of charging points, as well as the display of range and charging features.
- **Connected Music** offers unlimited streaming of millions of songs in the vehicle from Spotify.
- **Connected Parking** offers multi-story and on-street parking information in selected cities in the UK and Europe.
- **In-Car Experiences** takes care of you and adapts the interior ambience to suit your mood.
- **Real Time Traffic Information** supplies details about the location and duration of traffic delays.
- **Remote Services** allows you to remain connected to your vehicle from your phone.
- With **Smartphone Integration**, your vehicle supports Apple CarPlay® and Android Auto®. This way you can access your usual apps in the vehicle.

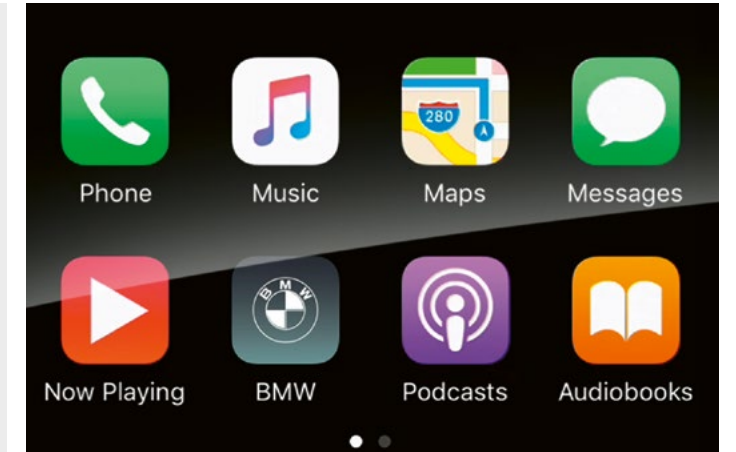

■ CONNECTED TEASER.

Three month trial of the following service:

- **BMW Music** brings your favourite soundtrack to your BMW.



MY BMW APP.

The My BMW App is the direct connection inside and outside your BMW. Plan your next trip, check the status of your vehicle or use one of the remote service functions – all conveniently from your smartphone.

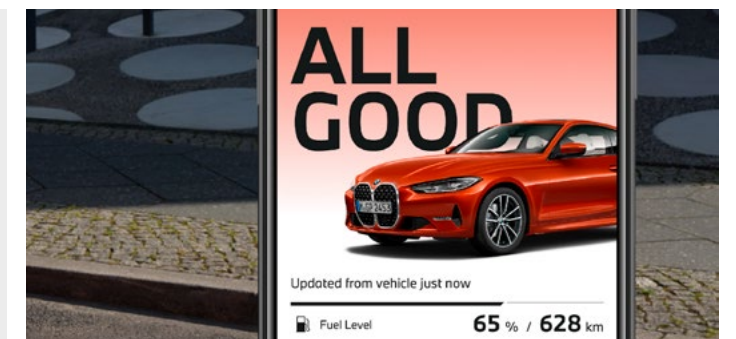

ELECTRIC DRIVING & CHARGING.

Soon after purchasing an electric car, you'll find that charging becomes more of an intuitive routine than a specific operation. Thanks to the portfolio of Products and Services available from BMW, which provide easy and convenient charging solutions, you can always rely on your new BMW iX3.

Using the cables provided, you can charge the high voltage battery via a conventional¹ 3-pin plug socket, or at any one of the extensive UK network of public charging stations. However, for regular fast charging BMW recommends that a dedicated private charging station (Wallbox) be installed. This ensures a faster and more convenient home charging experience.

Our official installation partner, bp pulse, guarantee a reliable solution from a single source, including consultation, delivery, installation and start-up. Please speak to your BMW Centre for more information.



eDRIVE TECHNOLOGY.

Encompassing a range of innovative elements, the fifth-generation BMW eDrive technology includes a drive unit with electric engine, power electronics and automatic transmission integrated together in a central housing unit. The new approach focuses on using recyclable and reusable materials for production, thus reducing global emissions.

SPECIFICATION & APPROXIMATE CHARGING TIME.

AC Charging – BMW Wallbox / Public	AC Charging – Public	DC Rapid Charging – Public	DC High-Power Charging – Public
AC Type 2 / Mode 3 / up to 7.4kW / 32Amps	AC Type 2 / Mode 3 / up to 11kW / 3 x 16Amps	DC Combo 2 / Mode 4 / up to 50kW	DC Combo 2 / Mode 4 / up to 150kW
<11.5 hours for 0-100% State of Charge	<7.5 hours for 0-100% State of Charge	<1.3 hours for 0-80% State of Charge	<34 minutes for 0-80% State of Charge

Charging times and information is provisional and subject to change. The design of the charging cable may vary from images shown. ¹ = It is advised that domestic electrical wiring is checked by a qualified electrician.

PUBLIC CHARGING.



ChargeNow is a service from BMW which, in partnership with bp pulse, enables customers in the UK to access the largest network of public charging points nationwide with a single card – the BMW ChargeNow charging card. Charging points are displayed directly in the navigation system, making it especially quick and easy to find and use public charging points. For a monthly fee of £7.85 and pay-as-you-charge access, payment is simple and cashless. You will receive a detailed itemised statement once a month and can access your account information online. Please speak to your BMW Centre for more information.

The design of the charging cable may vary from images shown.



CONNECTED CHARGING.

Thanks to the digital services available as part of Connected Charging, you can ensure that you get the best out of the electric range of the new BMW iX3. As soon as you start planning your trip, the system points you to the nearest public charging stations on your route and informs you in advance of their availability and the charging currents offered. To get the most out of the charging time, you will also be shown nearby points of interest, such as a café or restaurant.



CHARGING CABLE.

An essential for any journey, the Mode 3 charging cable allows you to conveniently charge the vehicle battery at public charging stations. It can be used for charging with up to 22kW charging capacity and is 5 metres in length. To get the most out of the charging time, you will also be shown nearby points of interest, such as a café or restaurant.

PRICING INFORMATION.



iX3 Premier Edition	iX3 Premier Edition Pro
---------------------	-------------------------

Basic price (excluding VAT)	£48,287.50	£50,787.50
VAT 20%	£9,657.50	£10,157.50
RRP (including VAT)	£57,945	£60,945
On the road price from	£58,850	£61,850
P11d value – Automatic	£58,795	£61,795
BIK tax rate (2020 / 2021)	0%	0%
Insurance group	44	45
RDE2 Compliant (Y / N)	N	N

PRICES AND SPECIFICATIONS

BMW (UK) Limited reserves the right to alter prices and specifications without notice. BMW (UK) Limited has made every effort to ensure the accuracy of information but does not accept liability for any errors or omissions.

VED RATES

Annual VED (second year onwards), for cars costing over £40,000, is payable for five years. VED rates for brand cars are determined by their CO₂ emissions figure. First year VED applies to the first year of ownership. Annual VED rates apply thereafter. The new BMW iX3 falls into the category below:

CO ₂ emissions – combined (g/km)	0
First year VED	£0
Annual VED – second year onwards (standard rate for electric vehicles)	£0
Annual VED – second year onwards (electric vehicles over £40,000)	£325



To find out more about the benefits of owning an ultra low emission vehicle, including the Government's grants for vehicles and chargepoints, visit www.GoUltraLow.com

ON THE ROAD PRICE

The recommended on the road price includes:

Delivery and BMW Emergency Service	£825
Number plates	£25
Vehicle first registration fee	£55
First year Vehicle Excise Duty	See left

These figures were obtained after the battery had been fully charged. The new BMW iX3 is a battery electric vehicle requiring mains electricity for charging. There is a new test for fuel consumption, CO₂ and electric range figures. The electric range shown was achieved using the new test procedure. Figures shown are for comparability purposes. Only compare fuel consumption, CO₂ and electric range figures with other cars tested to the same technical procedures. These figures may not reflect real life driving results, which will depend upon a number of factors including the starting charge of the battery, accessories fitted (post-registration), variations in weather, driving styles and vehicle load. The CO₂ figures shown above have been determined according to the WLTP test. WLTP has been used as the applicable CO₂ figure from 1 April 2020 for first year vehicle tax (VED) and from 6 April 2020 for company car tax (BIK). The CO₂ figures were previously based on the NEDC equivalent. Insurance group figures refer to 50 Group Rating System.

TECHNICAL INFORMATION.



	iX3 Premier Edition	iX3 Premier Edition Pro
--	---------------------	-------------------------

Power output (hp)	282	282
0-62mph / 0-100km/h (secs)	6.8	6.8
Fuel consumption – combined (mpg / l/100km)*	0	0
CO ₂ emissions – combined (g/km)*	0	0
Electric energy consumption – weighted combined (miles/kWh)*	3.3	3.3
Electric energy consumption – weighted combined (kWh/100km)*	18.9-18.8	19.0-18.9
Pure Electric Range – combined (miles)*	280.9-282.1	279.6-281.5
Pure Electric Range – combined (km)*	452.0-454.0	450.0-453.0

* = These figures were obtained after the battery had been fully charged. The BMW iX3 is a battery electric vehicle requiring mains electricity for charging. There is a new test for fuel consumption, CO₂ and electric range figures. The electric range shown was achieved using the new test procedure. Figures shown are for comparability purposes. Only compare fuel consumption, CO₂ and electric range figures with other cars tested to the same technical procedures. These figures may not reflect real life driving results, which will depend upon a number of factors including the starting charge of the battery, accessories fitted (post-registration), variations in weather, driving styles and vehicle load. The CO₂ figures shown above have been determined according to the WLTP test. WLTP has been used as the applicable CO₂ figure from 1 April 2020 for first year vehicle tax (VED) and from 6 April 2020 for company car tax (BIK). The CO₂ figures were previously based on the NEDC equivalent.

OPTIONAL EQUIPMENT PRICING.



	iX3 Premier Edition	iX3 Premier Edition Pro	Price
--	---------------------	-------------------------	-------

PAINTWORK

Metallic Available in Carbon Black, Mineral White, Phytonic Blue and Sophisto Grey	■	■	Std
---	---	---	-----

UPHOLSTERY

Vernasca leather Available in Black with Grey stitching, Canberra Beige with Roggen stitching, Cognac with Mocha stitching or Mocha with Blue stitching	■	■	Std
--	---	---	-----

INTERIOR TRIMS

High-gloss Black with Pearl Chrome finisher	■	■	Std
Aluminium fine-cutting with Pearl Chrome finisher	□	□	£0

EXTERIOR EQUIPMENT

Adaptive M suspension ¹	□	□	£450
Deletion of BMW i Blue exterior design elements	□	□	£0
Towbar, fully electric	□	□	£850

¹ = Available to purchase via the BMW ConnectedDrive store after vehicle production has been completed.



SAFETY & TECHNOLOGY

	IX3 Premier Edition	IX3 Premier Edition Pro	Price
Drive Recorder ¹ Comprises: – Crash recorder – Event recorder	-	■	Std
Driving Assistant Professional Comprises: – Active Cruise Control with Approach Control – Active Lane Guidance – Adaptive Distance Control – Automatic Speed Limit Assist – Lane Change Warning – Lane Departure Warning – Lane keeping assistant with active side collision protection – Steering and lane control assistant	■	■	Std
Parking Assistant Comprises: – Parking Assistant – Park Distance Control (PDC) – Reversing Assistant	■	■	Std
Parking Assistant Plus Comprises: – Parking Assistant – Surround View – Remote 3D View	-	■	Std

¹ = Please note that heavy accidents with hard disc damages or camera damages are owing to circumstances where videos may not be recorded or saved.



iX3 Premier Edition	iX3 Premier Edition Pro	Price
---------------------	-------------------------	-------

AUDIO & COMMUNICATION

BMW Emergency Call ¹	■	■	Std
BMW Live Cockpit Professional Comprises: – 10.25" Control Display with Touch Functionality – 12.3" Digital Instrument Display – BMW Intelligent Personal Assistant ² – BMW Operating System 7.0 – iDrive Controller with Touch Function – Intelligent Functionalities ² – Remote Software Upgrade ² For further details, see BMW ConnectedDrive	■	■	Std
BMW Online Services ^{2, 3} – BMW Apps – BMW Online Services – Last State Call ¹ – USB and Over-the-air Map Updates	■	■	Std
BMW TeleServices ¹	■	■	Std
Connected Package Professional ^{2, 3} Comprises: – BMW Maps – Concierge Services – Connected Music – Connected Parking – Connected Teaser ^{4, 5} – In-Car Experiences – Real Time Traffic Information – Remote 3D View (iX3 Premier Edition Pro only) – Remote Services – Smartphone Integration ^{1, 6} For further details, see BMW ConnectedDrive	■	■	Std
Enhanced Bluetooth with wireless charging	■	■	Std
IconicSounds	■	■	Std
Loudspeaker system – harman/kardon	-	■	Std
WiFi hotspot preparation ⁷	■	■	Std

¹ = Available and active without runtime limitations. Usage cannot be guaranteed permanently due to potential future technical developments (of the Service availability and/or Smartphone compatibility/operating systems). ² = Active for 3 years, renewable thereafter at an additional cost. ³ = Requires a free BMW ConnectedDrive account. ⁴ = Includes BMW Music for a three month trial. For further details, see [BMW ConnectedDrive](#). ⁵ = Available and active for three months. Can be extended or renewed thereafter at an extra cost. ⁶ = Functions using a data connection will use data from the SIM card in the phone. Additional data charges may be applied by the mobile network provider. Compatibility and functions may vary due to the make and model year of the phone and the version of software installed on it. ⁷ = Data subscription costs apply and must be purchased separately.

DIMENSIONS.

THE NEW BMW iX3.

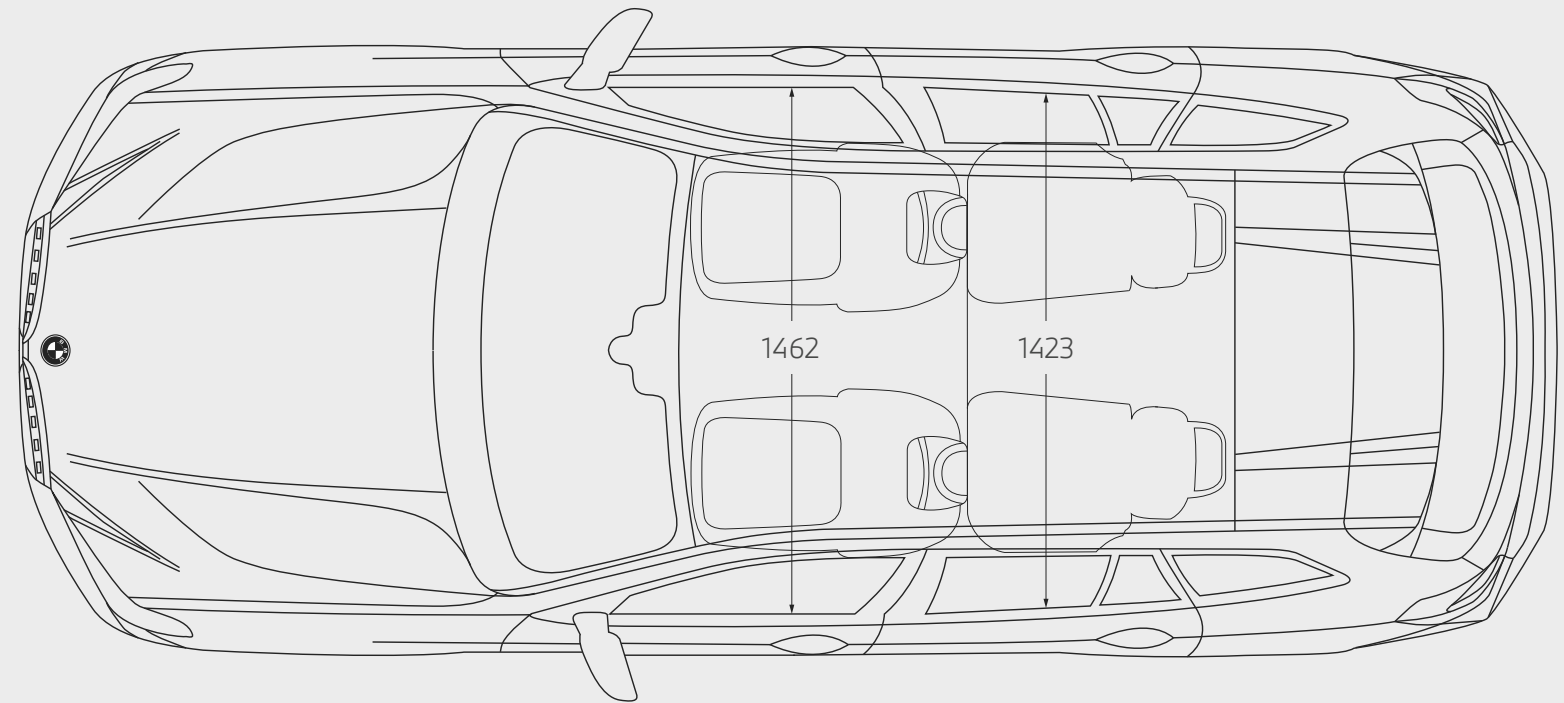
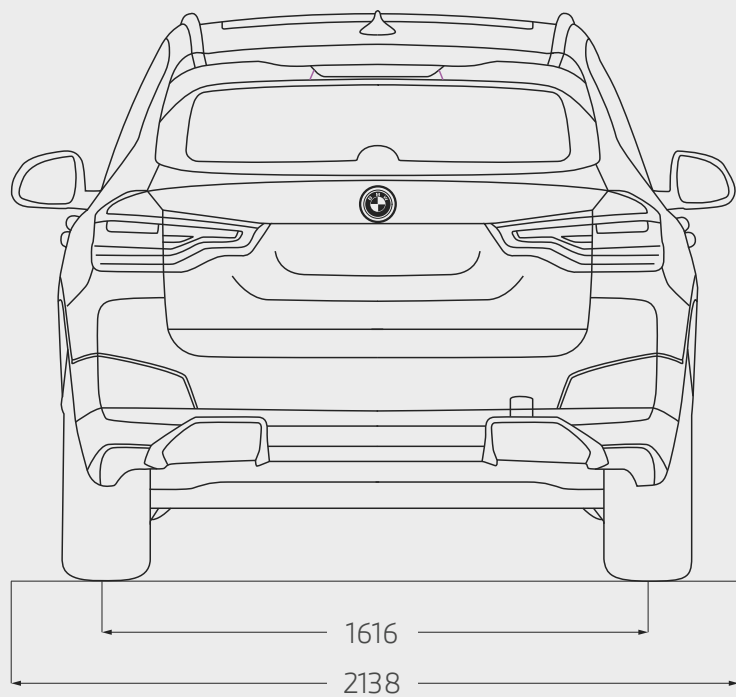
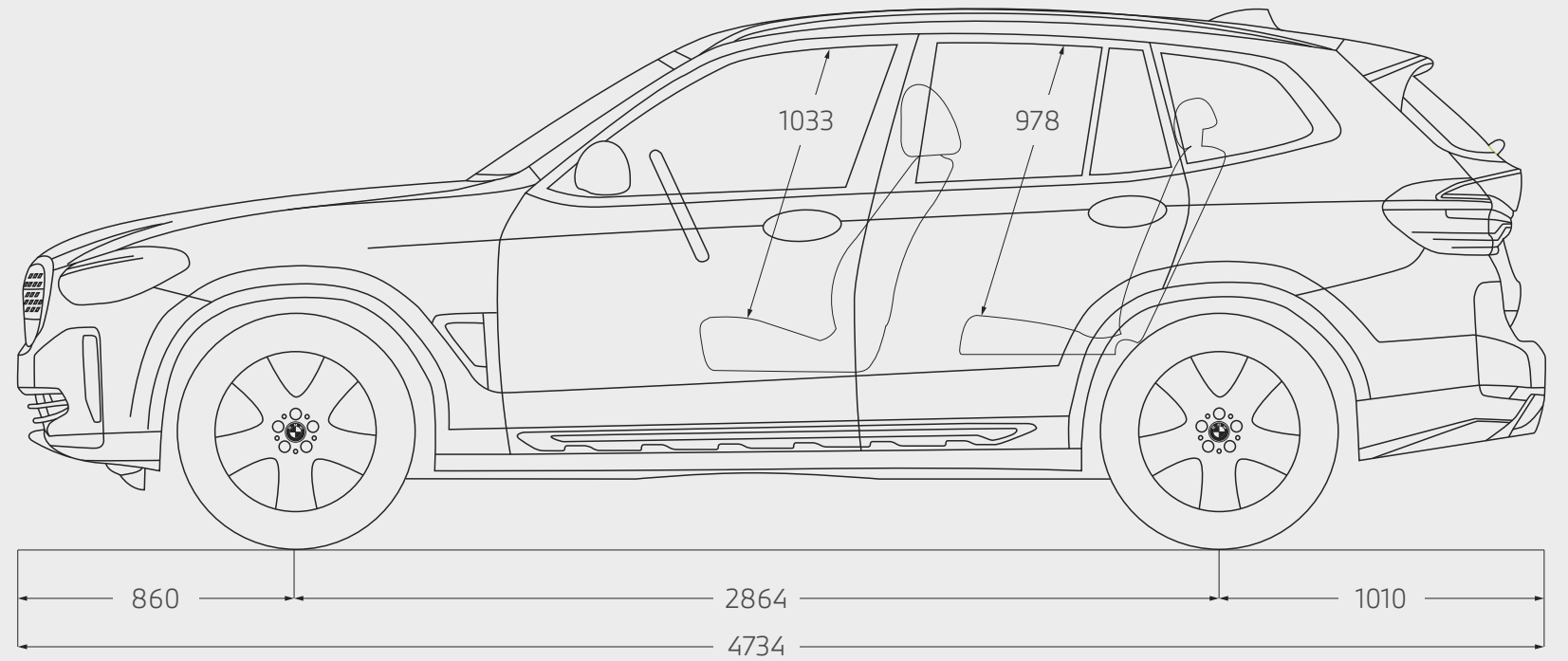
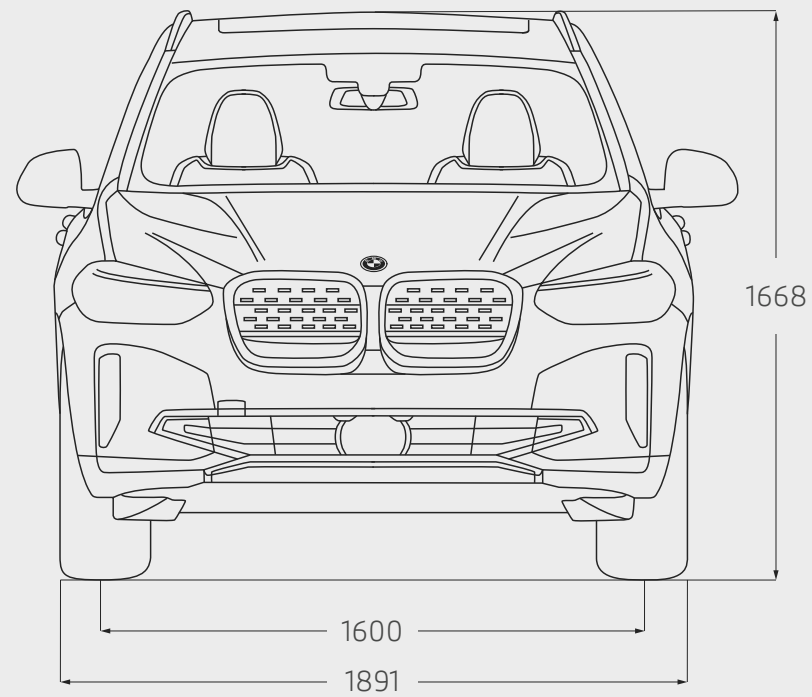

Length (mm)	4734	Height (mm)	1668	Number of seats	5	Turning circle (m)	12.1
Width (mm)	1891	Width including mirrors (mm) (Driver / Passenger)	2138 (1080 / 1058)	Wheelbase (mm)	2864	Luggage capacity (litre)	510-1560

BMW PAY MONTHLY SERVICING & TRACKSTAR.

SERVICING MADE SIMPLE.

Planning for the road ahead has never been easier. With the BMW Pay Monthly Service Plan¹ you can remove the uncertainty often associated with car servicing costs by spreading them monthly, much like you would your household bills. Our Pay Monthly service plan covers two services and any unused credit can be transferred to another BMW if you decide to switch unexpectedly. As part of the Pay Monthly plan you will also receive a number of added extras including:

- Fluid top ups
- An MOT
- A Wash & Vac each time you visit
- Seasonal health checks
- Sat Nav Map updates

Get the quality service and parts you expect from BMW with a fixed monthly payment. Give your BMW the care and attention it deserves from the experts that made it.

Price: TBC

Please contact your preferred BMW Centre for further information.

BMW TRACKSTAR.

Locate and recover your vehicle if it is stolen with BMW Trackstar or BMW Trackstar Advance. Benefits include:

- 24/7 Trackstar Monitoring Centre
- Thatcham accredited
- Integrated motion sensor
- Pan-European protection

BMW Trackstar S7 price from: TBC

BMW Trackstar S5 price from TBC

BMW Trackstar S5 Advance price from: TBC



BMW CONNECTED DRIVE SERVICES.

BMW ConnectedDrive keeps driver and vehicle connected with the outside world. Digital services, driver-focused technologies and driver assistance systems provide more comfort, more entertainment and more safety. Increase your driving pleasure – with BMW ConnectedDrive.

For further information on BMW ConnectedDrive and the General Terms and Conditions of Service for ConnectedDrive, please see: www.bmw.co.uk/connecteddrive-information

The BMW ConnectedDrive Hotline is available on: +44 (0) 800 561 0555 from Monday to Friday 8am – 7pm and Saturday to Sunday 9am – 5pm.

CONNECTED DRIVE SERVICES DURATION

BMW Music	3 month trial
BMW Apps	3 years
BMW Intelligent Personal Assistant	3 years
BMW Maps	3 years
BMW Online Services	3 years
Concierge Services	3 years
Connected Charging	3 years
Connected Music	3 years
Connected Parking	3 years
In-Car Experiences	3 years
Intelligent Functionalities	3 years
Map Updates	3 years
Real Time Traffic Information	3 years
Remote Services	3 years
Remote Software Upgrade	3 years
BMW Emergency Call	Active without runtime limitations
BMW TeleServices	Active without runtime limitations
Last State Call	Active without runtime limitations
Smartphone Integration	Active without runtime limitations

GENERAL INFORMATION

BMW (UK) Ltd, Summit ONE, Summit Avenue, Farnborough, Hampshire, GU14 0FB (hereinafter referred to as "BMW") provides the customer with certain vehicle-related information and assistance functions (hereinafter called "Services") under the name of "BMW ConnectedDrive". BMW collects, stores or processes car-related data in compliance with applicable law and only to the extent necessary to provide the Services. BMW does not collect, store or process personal data in course of the Services – except where this is explicitly stated in the service description of the individual Services. In the case of Services that require personal data to be collected, stored and processed so that such Services can actually be provided, BMW informs customers of this in advance by providing this data protection notice. The Services are provided by means of a SIM card installed in the vehicle.

DEACTIVATION

You can have the BMW ConnectedDrive services deactivated through an authorised BMW centre, a BMW subsidiary or a BMW authorised workshop at any time. This also has the consequence that aspects of the emergency call in the vehicle as well as all remaining Services will no longer function.

You can additionally arrange for the remaining Services to be deactivated via "My BMW ConnectedDrive".

If the vehicle is equipped with the legally required EU Emergency Call (as from April 2018) a deactivation of the BMW ConnectedDrive basic services will not deactivate the vehicle's built-in SIM card. It has to remain active, so that the EU Emergency Call is functional all the time.

Services that are available and active without runtime limitations, cannot be guaranteed for permanent usage due to potential future technical developments (of the Service availability and/or Smartphone compatibility/operating systems).





READY TO TAKE THE NEXT STEP?

